

100-watt + 100-watt dual BTL class-D audio amplifier

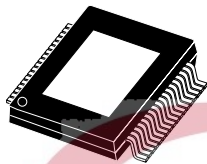

PowerSSO-36
exposed pad up

Features

- 100 W + 100 W output power at THD = 10% with $R_L = 6 \Omega$ and $V_{CC} = 36 \text{ V}$
- 80 W + 80 W output power at THD = 10% with $R_L = 8 \Omega$ and $V_{CC} = 34 \text{ V}$
- Wide-range single-supply operation (14 - 39 V)
- High efficiency ($\eta = 90\%$)
- Four selectable, fixed gain settings of nominally 25.6 dB, 31.6 dB, 35.1 dB and 37.6 dB
- Differential inputs minimize common-mode noise
- Standby and mute features
- Short-circuit protection
- Thermal overload protection
- Externally synchronizable

Description

The TDA7498 is a dual BTL class-D audio amplifier with single power supply designed for home systems and active speaker applications.

It comes in a 36-pin PowerSSO package with exposed pad up (EPU) to facilitate mounting a separate heatsink.

Product status link

[TDA7498](#)

Product summary

Order code	TDA7498TR
Temperature range	-40 to 85 °C
Package	PowerSSO36 (EPU)
Packing	Tape and reel

SKYTECH
ELECTRONIC

1 Device block diagram

Figure 1. Internal block diagram (showing one channel only) shows the block diagram of one of the two identical channels of the TDA7498.

Figure 1. Internal block diagram (showing one channel only)

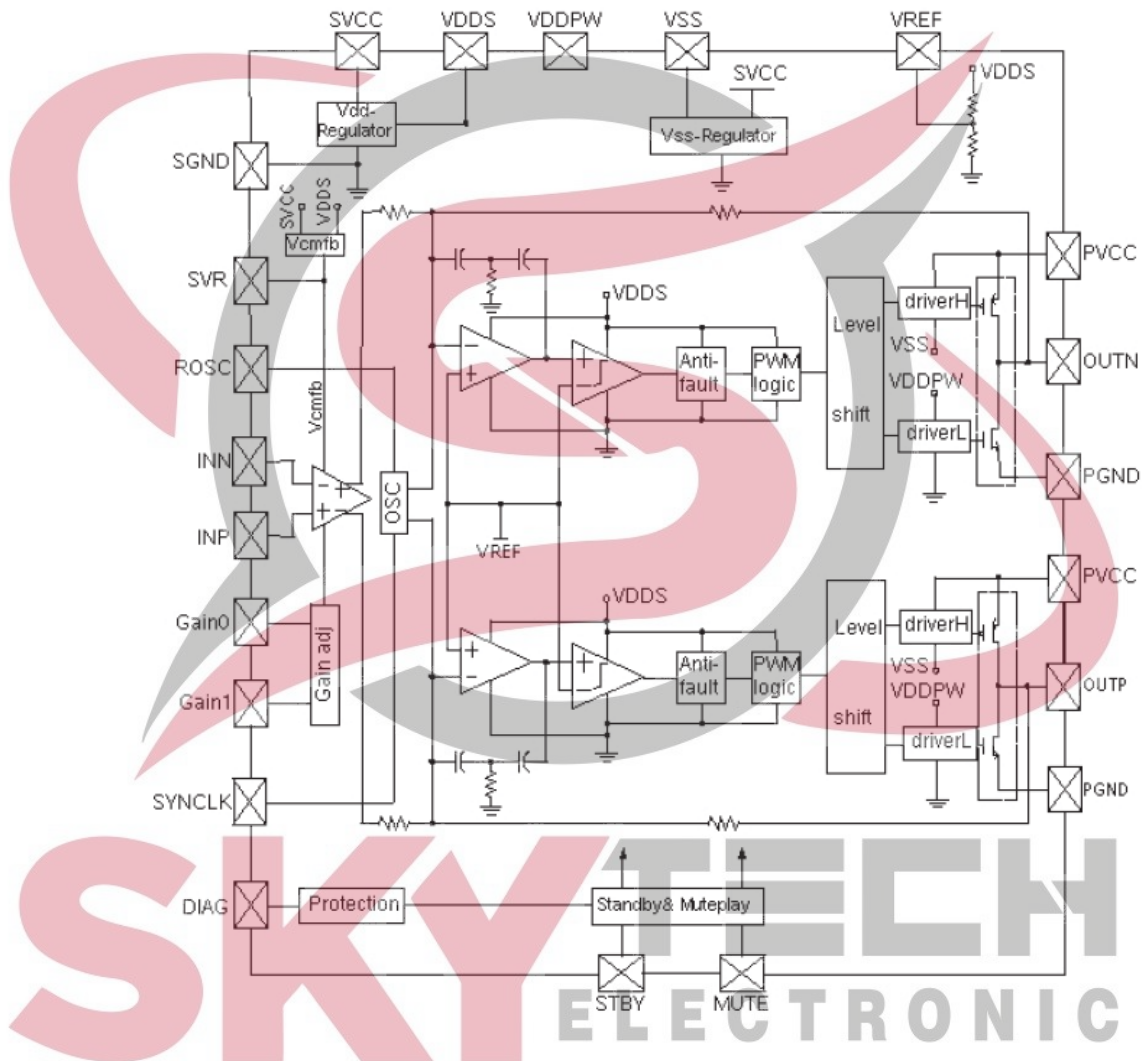

2 Pin description

2.1 Pinout

Figure 2. Pin connections (top view, PCB view)

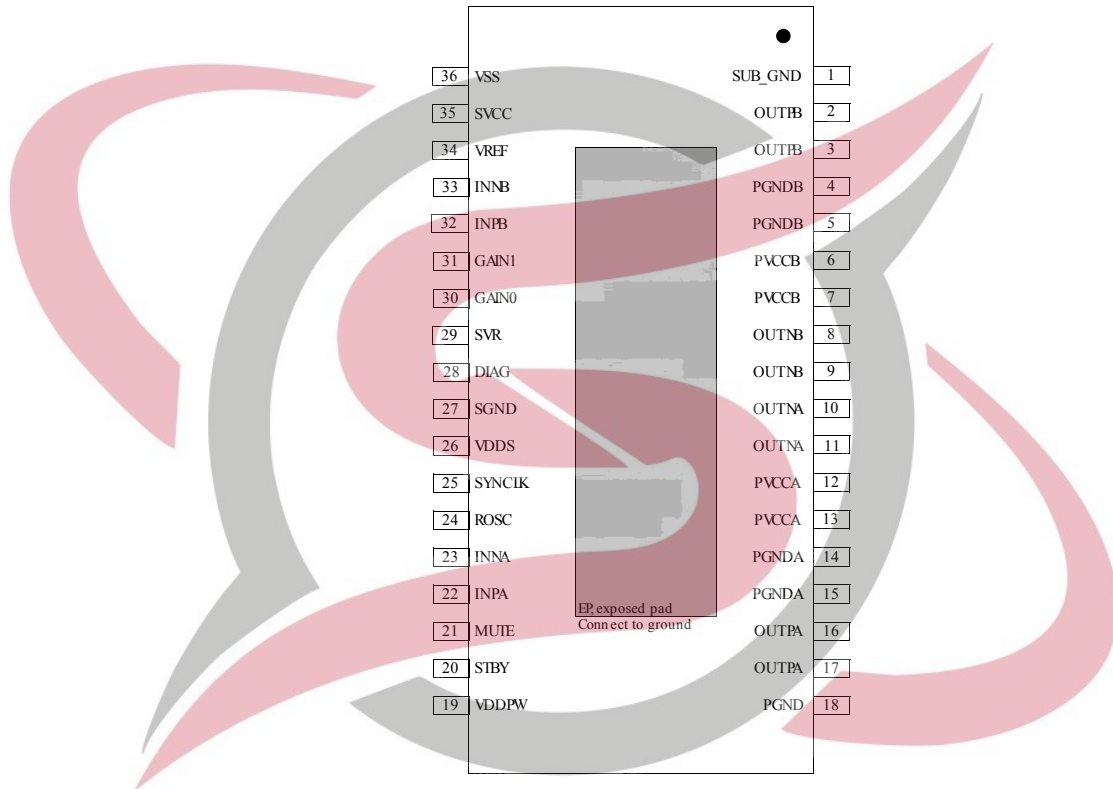

SKYTECH
ELECTRONIC

2.2 Pin list

Table 1. Pin description list

Number	Name	Type	Description
1	SUB_GND	PWR	Connect to the frame
2,3	OUTPB	O	Positive PWM for right channel
4,5	PGNDB	PWR	Power stage ground for right channel
6,7	PVCCB	PWR	Power supply for right channel
8,9	OUTNB	O	Negative PWM output for right channel
10,11	OUTNA	O	Negative PWM output for left channel
12,13	PVCCA	PWR	Power supply for left channel
14,15	PGNDA	PWR	Power stage ground for left channel
16,17	OUTPA	O	Positive PWM output for left channel
18	PGND	PWR	Power stage ground
19	VDDPW	O	3.3-V (nominal) regulator output referred to ground for power stage
20	STBY	I	Standby mode control
21	MUTE	I	Mute mode control
22	INPA	I	Positive differential input of left channel
23	INNA	I	Negative differential input of left channel
24	ROSC	O	Master oscillator frequency-setting pin
25	SYNCLK	I/O	Clock in/out for external oscillator
26	VDDS	O	3.3-V (nominal) regulator output referred to ground for signal blocks
27	SGND	PWR	Signal ground
28	DIAG	O	Open-drain diagnostic output
29	SVR	O	Supply voltage rejection
30	GAIN0	I	Gain setting input 1
31	GAIN1	I	Gain setting input 2
32	INPB	I	Positive differential input of right channel
33	INNB	I	Negative differential input of right channel
34	VREF	O	Half VDDS (nominal) referred to ground
35	SVCC	PWR	Signal power supply
36	VSS	O	3.3-V (nominal) regulator output referred to power supply
-	EP	-	Exposed pad for heatsink, to be connected to ground

3 Electrical specifications

3.1 Absolute maximum ratings

Table 2. Absolute maximum ratings

Symbol	Parameter	Value	Unit
V _{CC}	DC supply voltage for pins PVCCA, PVCCB, SVCC	45	V
V _I	Voltage limits for input pins STBY, MUTE, INNA, INPA, INNB, INPB, GAIN0, GAIN1	-0.3 to 3.6	V
T _j	Operating junction temperature	-40 to 150	°C
T _{stg}	Storage temperature	-40 to 150	°C

3.2 Thermal data

Table 3. Thermal data

Symbol	Parameter	Min.	Typ.	Max.	Unit
R _{th j-case}	Thermal resistance, junction to case	-	2	3	°C/W

3.3 Recommended operating conditions

Table 4. Recommended operating conditions

Symbol	Parameter	Min.	Typ.	Max.	Unit
V _{CC}	Supply voltage for pins PVCCA, PVCCB, SVCC	14	-	39	V
T _{amb}	Ambient operating temperature	-40	-	85	°C

3.4 Electrical specifications

Unless otherwise stated, the values in the table below are specified for the conditions: V_{CC} = 36 V, R_L = 6 Ω, R_{OSC} = R₃ = 39 kΩ, C₈ = 100 nF, f = 1 kHz, G_V = 25.6 dB T_{amb} = 25 °C.

Table 5. Electrical specifications

Symbol	Parameter	Conditions	Min.	Typ.	Max.	Unit
I _q	Total quiescent current	No LC filter, no load	-	40	60	mA
I _{qSTBY}	Quiescent current in standby	-	-	1	10	μA
V _{OS}	Output offset voltage	Play mode	-100	-	100	mV
		Mute mode	-60	-	60	
I _{OCP}	Overcurrent protection threshold	R _L = 0 Ω	6	7	-	A
T _j	Junction temperature at thermal shutdown	-	-	150	-	°C
R _i	Input resistance	Differential input	48	60	-	kΩ
V _{OVP}	Overvoltage protection threshold	-	42	43	-	V

Symbol	Parameter	Conditions	Min.	Typ.	Max.	Unit
V _{UVP}	Undervoltage protection threshold	-	-	-	8	V
R _{dsON}	Power transistor on-resistance	High side	-	0.2	-	Ω
		Low side	-	0.2	-	
P _o	Output power	THD = 10%	-	100	-	W
		THD = 1%	-	78	-	
P _o	Output power	R _L = 8 Ω, THD = 10%	-	80	-	W
P _D	Dissipated power	P _o = 100 W + 100 W, THD = 10%	-	20	-	W
η	Efficiency	P _o = 100 W + 100 W	-	90	-	%
THD	Total harmonic distortion	P _o = 1 W	-	0.1	-	%
G _V	Closed-loop gain	GAIN0 = L, GAIN1 = L	24.6	25.6	26.6	dB
		GAIN0 = L, GAIN1 = H	30.6	31.6	32.6	
		GAIN0 = H, GAIN1 = L	34.1	35.1	36.1	
		GAIN0 = H, GAIN1 = H	36.6	37.6	38.6	
ΔG _V	Gain matching	-	-1	-	1	dB
C _T	Crosstalk	f = 1 kHz, P _o = 1 W	50	70	-	dB
eN	Total input noise	A Curve, G _V = 20 dB	-	15	-	μV
		f = 22 Hz to 22 kHz	-	25	50	
SVRR	Supply voltage rejection ratio	f _r = 100 Hz, V _r = 0.5 V _{pp} , C _{SVR} = 10 μF	-	70	-	dB
T _r , T _f	Rise and fall times	-	-	50	-	ns
f _{SW}	Switching frequency	Internal oscillator	290	310	330	kHz
f _{SWR}	Output switching frequency range	With internal oscillator ⁽¹⁾	250	-	400	kHz
		With external oscillator ⁽²⁾	250	-	400	
V _{inH}	Digital input high (H)	-	2.3	-	-	V
V _{inL}	Digital input low (L)	-	-	-	0.8	
V _{STBY}	Pin STBY voltage high (H)	-	2.7	-	-	V
	Pin STBY voltage low (L)	-	-	-	0.5	
V _{MUTE}	Pin MUTE voltage high (H)	-	2.5	-	-	V
	Pin MUTE voltage low (L)	-	-	-	0.8	
A _{MUTE}	Mute attenuation	V _{MUTE} = L, V _{STBY} = H	-	70	-	dB

1. $f_{SW} = 10^6 / ((16 * R_{OSC} + 182) * 4)$ kHz, $f_{SYNCLK} = 2 * f_{SW}$ with R3 = 39 kΩ (see Figure 19. Application circuit for 6 Ω or 8 Ω speakers).

2. $f_{SW} = f_{SYNCLK} / 2$ with the external oscillator.

4 Characterization curves

4.1 Test circuit

Figure 3. Test circuit for characterizations shows the test circuit with which the characterization curves, shown in the next sections, were measured. Figure 4. Test board shows the PCB layout.

Figure 3. Test circuit for characterizations

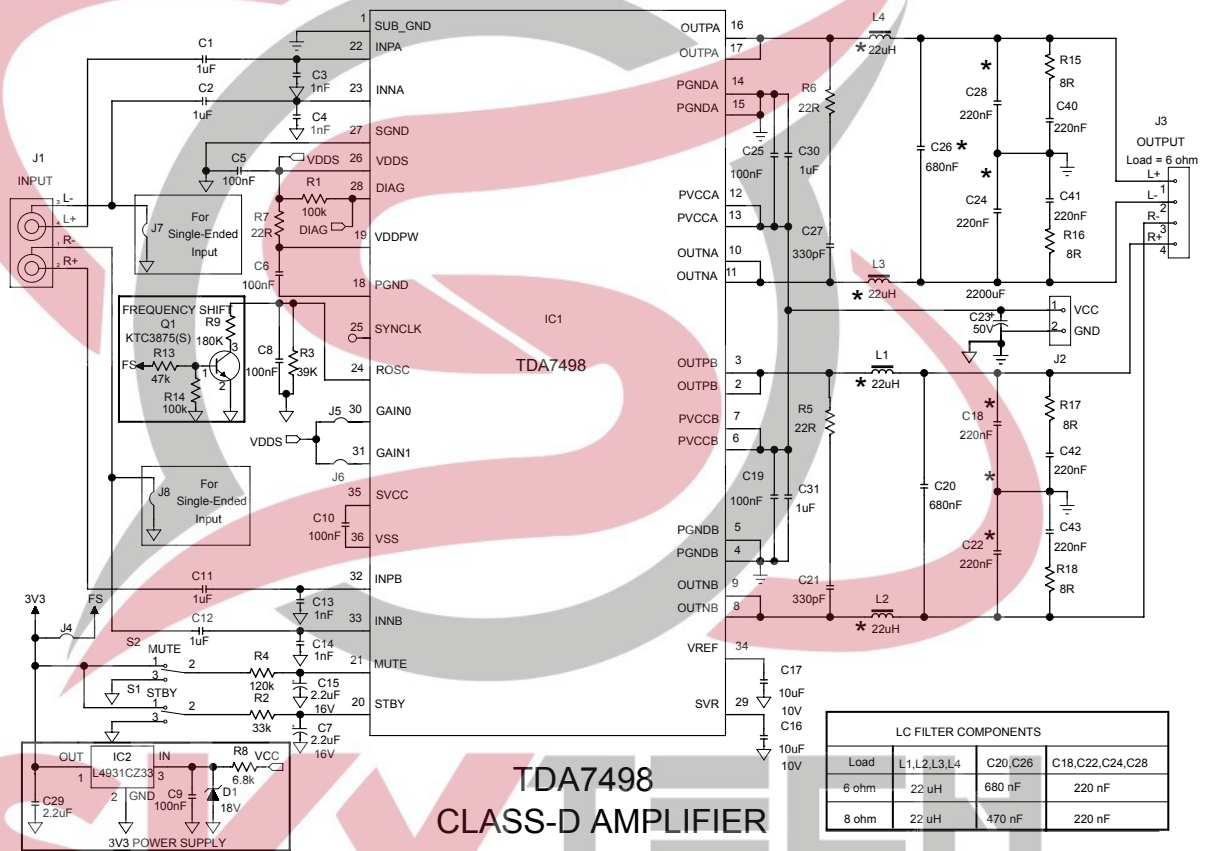
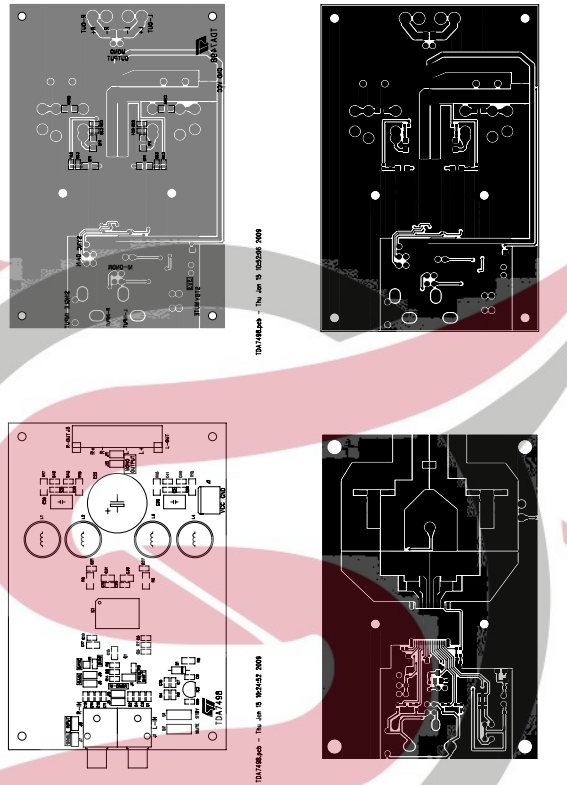

Figure 4. Test board



4.2 Characterization curves

Unless otherwise stated the measurements were made under the following conditions:

$V_{CC} = 36\text{ V}$, $f = 1\text{ kHz}$, $G_V = 25.6\text{ dB}$, $R_{OSC} = 39\text{ k}\Omega$, $C_{OSC} = 100\text{ nF}$, $T_{amb} = 25\text{ }^\circ\text{C}$

SKYTECH
ELECTRONIC

4.2.1 For $R_L = 6 \Omega$

Figure 5. Output power (THD = 10%) vs. supply voltage

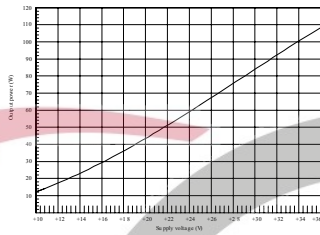

Figure 6. THD vs. output power

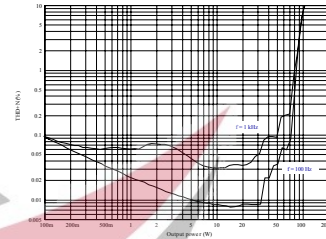

Figure 7. THD vs. frequency (1 W)

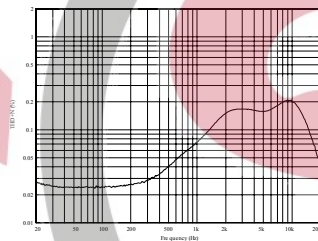

Figure 8. THD vs. frequency (100 mW)

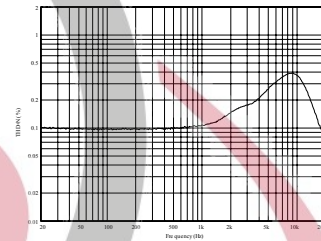

Figure 9. Frequency response

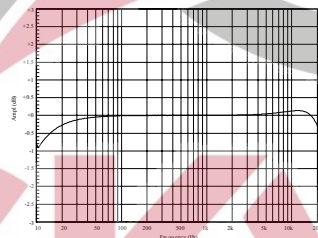

Figure 10. FFT performance (0 dBFS)

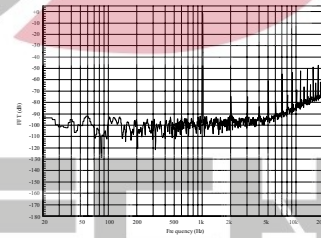
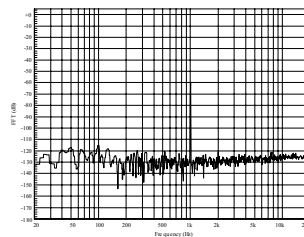

Figure 11. FFT performance (-60 dBFS)



SKYTECH ELECTRONIC

4.2.2 For $R_L = 8 \Omega$

Figure 12. Output power (THD = 10%) vs. supply voltage

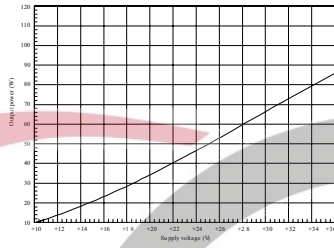

Figure 13. THD vs. output power

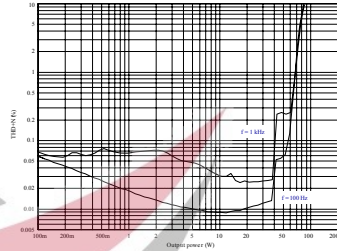

Figure 14. THD vs. frequency (1 W)

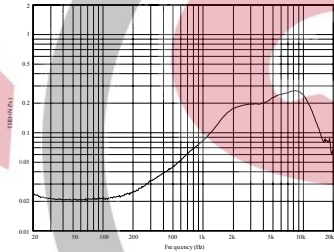

Figure 15. THD vs. frequency (100 mW)

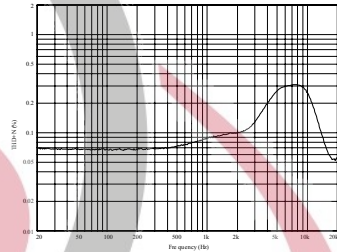

Figure 16. Frequency response

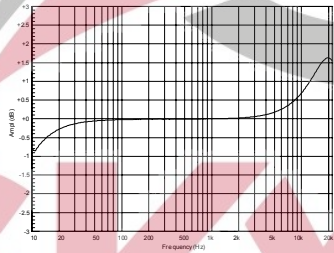

Figure 17. FFT performance (0 dB)

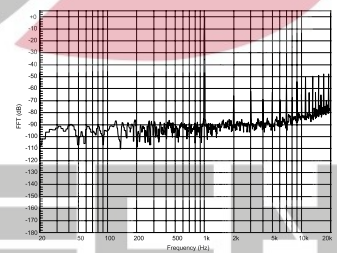
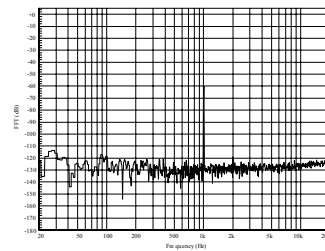

Figure 18. FFT performance (-60 dB)



SKYTECH
ELECTRONIC

5 Application information

5.1 Application circuit

Figure 19. Application circuit for 6 Ω or 8 Ω speakers

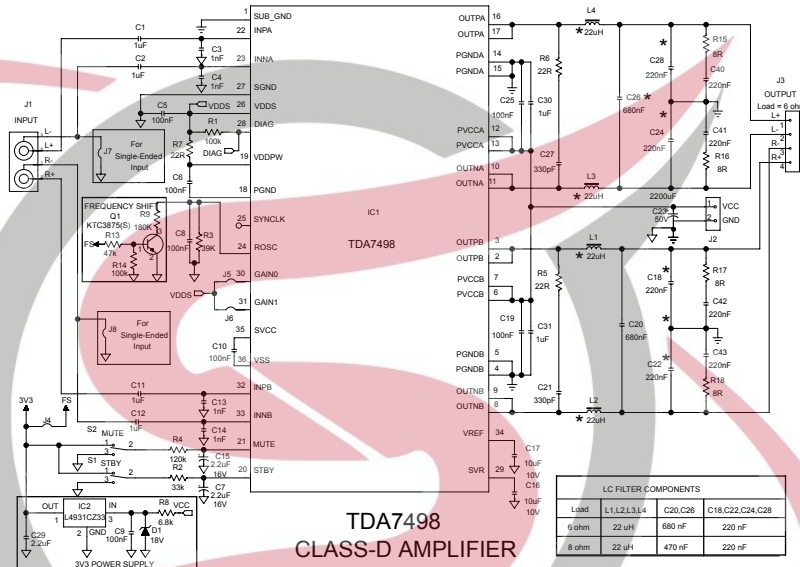

5.2 Mode selection

The three operating modes of the TDA7498 are set by the two inputs, STBY (pin 20) and MUTE (pin 21).

- Standby mode: all circuits are turned off, very low current consumption.
- Mute mode: inputs are connected to ground and the positive and negative PWM outputs are at 50% duty cycle.
- Play mode: the amplifiers are active.

The protection functions of the TDA7498 are enabled by pulling down the voltages of the STBY and MUTE inputs shown in Figure 20. Standby and mute circuits. The input current of the corresponding pins must be limited to 200 μA.

Table 6. Mode settings

Mode	STBY	MUTE
Standby	L (1)	X (don't care)
Mute	H (1)	L
Play	H	H

1. Drive levels defined in Table 5. Electrical specifications

Figure 20. Standby and mute circuits

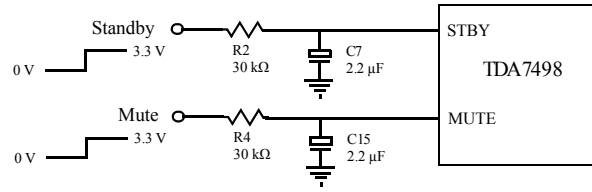
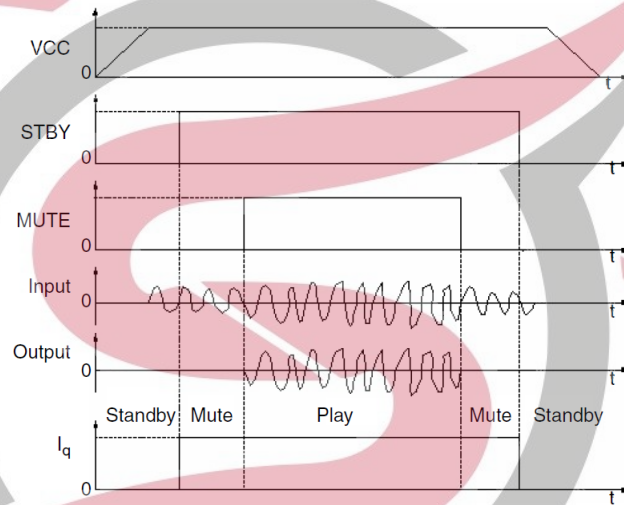

Figure 21. Turn on/off sequence for minimizing speaker “pop”



5.3 Gain setting

The gain of the TDA7498 is set by the two inputs, GAIN0 (pin 30) and GAIN1 (pin31). Internally, the gain is set by changing the feedback resistors of the amplifier.

Table 7. Gain settings

GAIN0	GAIN1	Nominal gain, G_v (dB)
L	L	25.6
L	H	31.6
H	L	35.6
H	H	37.6

5.4 Input resistance and capacitance

The input impedance is set by an internal resistor $R_i = 60 \text{ k}\Omega$ (typical). An input capacitor (C_i) is required to couple the AC input signal.

The equivalent circuit and frequency response of the input components are shown in Figure 22. Input circuit and frequency response. For $C_i = 470 \text{ nF}$ the high-pass filter cutoff frequency is below 20 Hz:

$$f_c = 1 / (2 * \pi * R_i * C_i)$$

Figure 22. Input circuit and frequency response

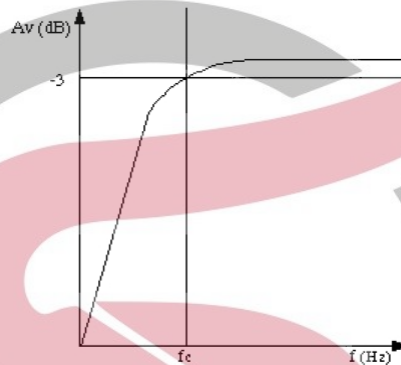
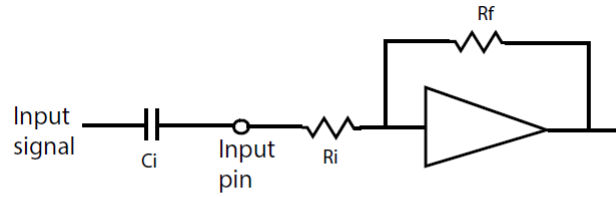

5.5 Internal and external clocks

The clock of the class-D amplifier can be generated internally or can be driven by an external source. If two or more class-D amplifiers are used in the same system, it is recommended that all devices operate at the same clock frequency. This can be implemented by using one TDA7498 as master clock, while the other devices are in slave mode, that is, externally clocked. The clock interconnect is via pin SYNCLK of each device. As explained below, SYNCLK is an output in master mode and an input in slave mode.

5.5.1 Master mode (internal clock)

Using the internal oscillator, the output switching frequency, f_{SW} , is controlled by the resistor, R_{OSC} , connected to pin ROSC:

$$f_{SW} = 10^6 / [(R_{OSC} * 16 + 182) * 4] \text{ kHz}$$

where R_{OSC} is in $k\Omega$.

In master mode, pin SYNCLK is used as a clock output pin whose frequency is:

$$f_{SYNCLK} = 2 * f_{SW}$$

For master mode to operate correctly then resistor R_{OSC} must be less than 60 $k\Omega$ as given below in Table 8. How to set up SYNCLK.

5.5.2 Slave mode (external clock)

In order to accept an external clock input the pin ROSC must be left open, that is, floating. This forces pin SYNCLK to be internally configured as an input as given in Table 8. How to set up SYNCLK.

The output switching frequency of the slave devices is:

$$f_{SW} = f_{SYNCLK} / 2$$

Table 8. How to set up SYNCLK

Mode	ROSC	SYNCLK
Master	$R_{OSC} < 60 \text{ k}\Omega$	Output
Slave	Floating (not connected)	Input

Figure 23. Master and slave connection

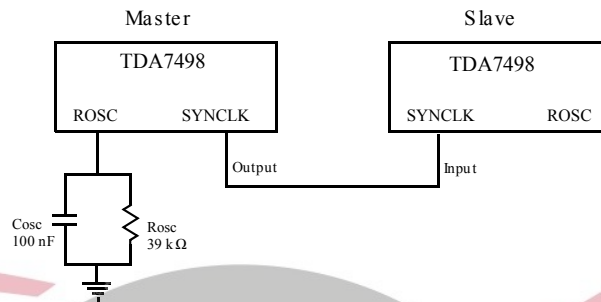

5.6 Output low-pass filter

To avoid EMI problems, it may be necessary to use a low-pass filter before the speaker. The cutoff frequency should be larger than 22 kHz and much lower than the output switching frequency. It is necessary to choose the L and C component values depending on the loudspeaker impedance. Some typical values, which give a cutoff frequency of 27 kHz, are shown in Figure 24. Typical LC filter for an 8 Ω speaker and Figure 25. Typical LC filter for a 6 Ω speaker below.

Figure 24. Typical LC filter for an 8 Ω speaker

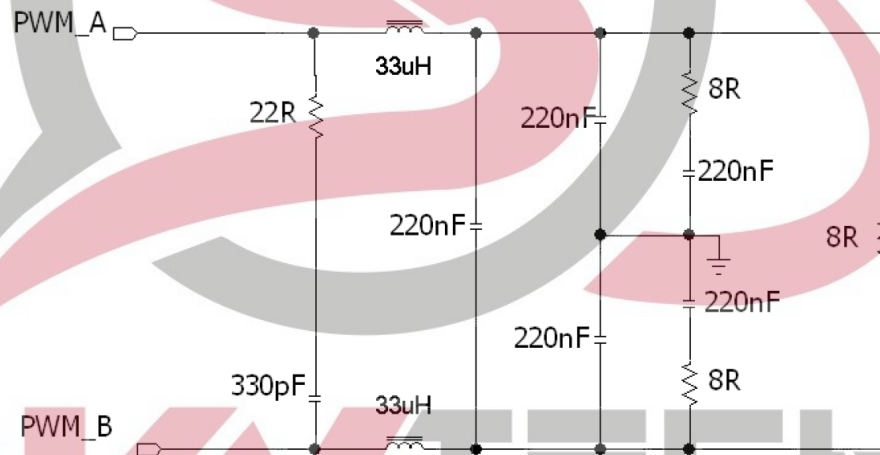
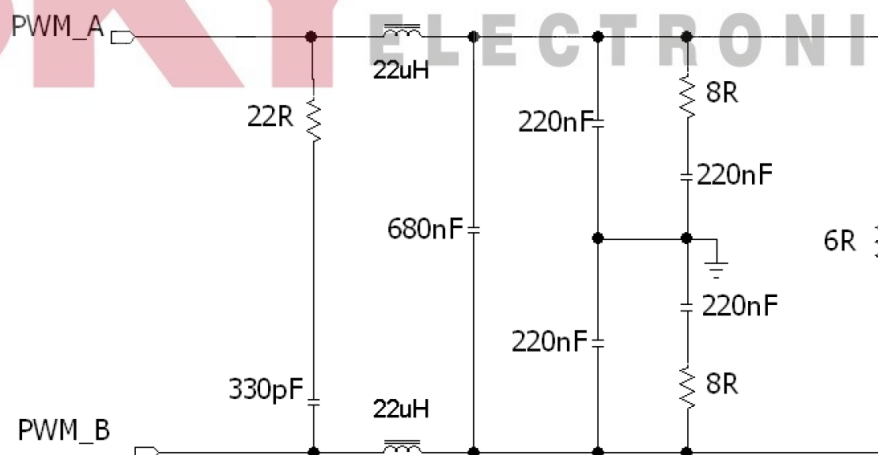

Figure 25. Typical LC filter for a 6 Ω speaker



5.7 Protection functions

The TDA7498 is fully protected against overvoltages, undervoltages, overcurrents and thermal overloads as explained here.

Overvoltage protection (OVP)

If the supply voltage exceeds the value for V_{OVP} given in Table 5. Electrical specifications , the overvoltage protection is activated which forces the outputs to the high-impedance state. When the supply voltage falls back to within the operating range, the device restarts.

Undervoltage protection (UVP)

If the supply voltage drops below the value for V_{UVP} given in Table 5. Electrical specifications , the undervoltage protection is activated which forces the outputs to the high-impedance state. When the supply voltage falls back to within the operating range, the device restarts.

Overcurrent protection (OCP)

If the output current exceeds the value for I_{OCP} given in Table 5. Electrical specifications , the overcurrent protection is activated which forces the outputs to the high-impedance state. Periodically, the device attempts to restart. If the overcurrent condition is still present, then the OCP remains active. The restart time, T_{OC} , is determined by the RC components connected to pin STBY.

Thermal protection (OTP)

If the junction temperature, T_j , reaches 145 °C (nominally), the device goes to mute mode and the positive and negative PWM outputs are forced to 50% duty cycle. If the junction temperature reaches the value for T_j given in Table 5. Electrical specifications , the device shuts down and the output is forced to the high-impedance state. When the device cools sufficiently the device restarts.

5.8 Diagnostic output

The output pin DIAG is an open-drain transistor. When any protection is activated, it switches to the high-impedance state. The pin can be connected to a power supply (< 39 V) by a pull-up resistor whose value is limited by the maximum sinking current (200 μ A) of the pin.

Figure 26. Behavior of pin DIAG for various protection conditions

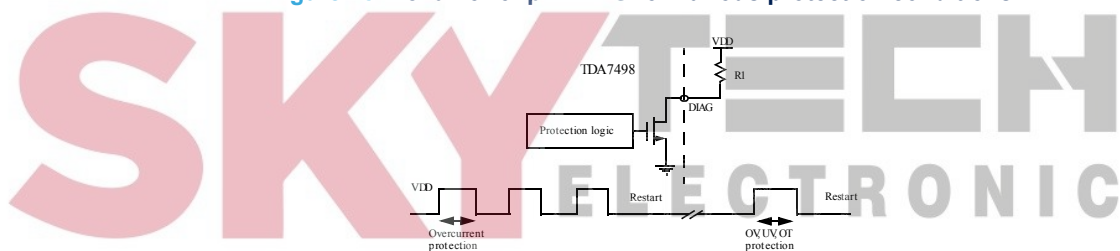

6 Package information

In order to meet environmental requirements, ST offers these devices in different grades of **ECOPACK** packages, depending on their level of environmental compliance. ECOPACK specifications, grade definitions and product status are available at: www.st.com. ECOPACK is an ST trademark.

6.1 PowerSSO-36 EPU package information

Figure 27. PowerSSO-36 EPU package outline

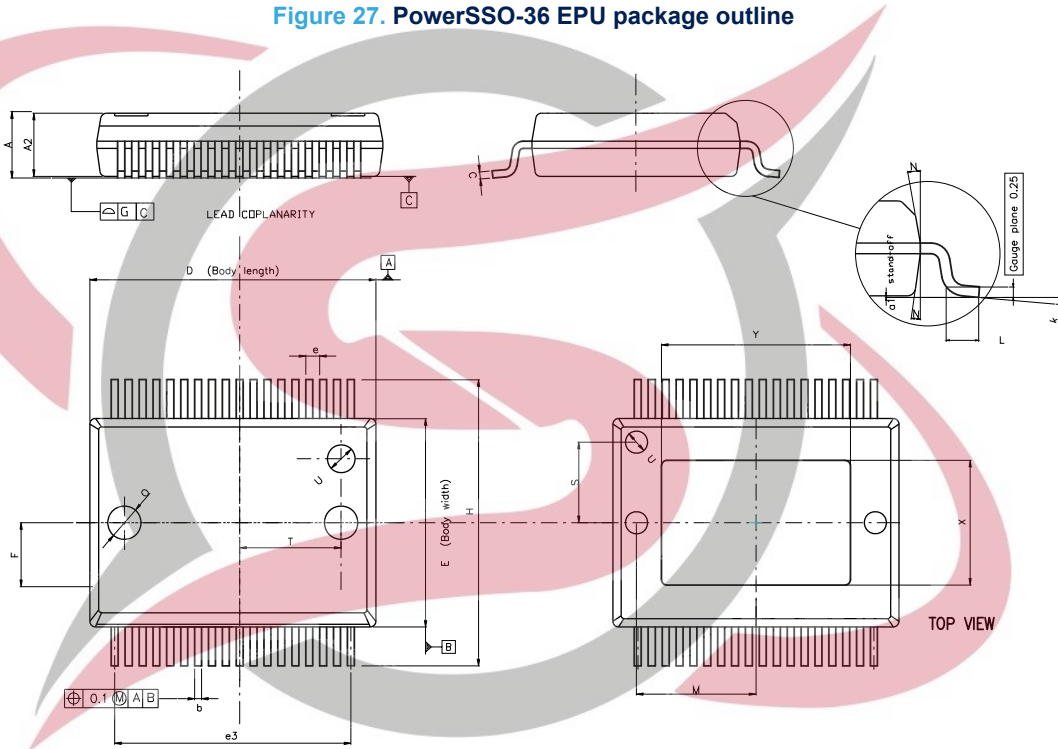

SKYTECH
ELECTRONIC

Table 9. PowerSSO-36 EPU package mechanical data

Symbol	mm			inches		
	Min.	Typ.	Max.	Min.	Typ.	Max.
A	2.15	-	2.45	0.085	-	0.096
A2	2.15	-	2.35	0.085	-	0.093
a1	0	-	0.10	0	-	0.004
b	0.18	-	0.36	0.007	-	0.014
c	0.23	-	0.32	0.009	-	0.013
D	10.10	-	10.50	0.398	-	0.413
E	7.40	-	7.60	0.291	-	0.299
e	-	0.5	-	-	0.020	-
e3	-	8.5	-	-	0.335	-
F	-	2.3	-	-	0.091	-
G	-	-	0.10	-	-	0.004
H	10.10	-	10.50	0.398	-	0.413
h	-	-	0.40	-	-	0.016
k	0	-	8 degrees	0	-	8 degrees
L	0.55	-	0.85	0.022	-	0.033
M	-	4.30	-	-	0.169	-
N	-	-	10 degrees	-	-	10 degrees
O	-	1.20	-	-	0.047	-
Q	-	0.80	-	-	0.031	-
S	-	2.90	-	-	0.114	-
T	-	3.65	-	-	0.144	-
U	-	1.00	-	-	0.039	-
X	4.10	-	4.70	0.161	-	0.185
Y	6.50	-	7.10	0.193	-	0.280



Revision history

Table 10. Document revision history

Date	Revision	Changes
11-Aug-2009	1	Initial release.
27-Aug-2009	2	Updated supply voltage range on page 1. Updated package exposed pad dimension Y (Min) in Section 6.1 .
23-Oct-2009	3	Updated first feature on page 1. Updated order code name in Section Updated Table 5. Electrical specifications Updated Section 4.2 Characterization curves Removed tables for standby, mute and gain after Figure 19. Application circuit for 6 Ω or 8 Ω speakers.
30-Jun-2010	4	Removed datasheet preliminary status, updated features list and updated Section Added Table 4. Recommended operating conditions with updated minimum supply voltage.
27-Jan-2011	5	Updated applications circuit in Figure 19. Application circuit for 6 Ω or 8 Ω speakers.
11-Feb-2011	6	Updated test circuit for characterizations in Section 4.1 .
29-Mar-2011	7	Updated I _{OCF} in Table 5. Electrical specifications .
12-Sep-2011	8	Updated OUTNA in Table 1. Pin description list
09-Sep-2015	9	Updated V _{CC} in Table 2. Absolute maximum ratings and dimension L in Section 6.1
28-Aug-2020	10	Removed order code for tube version.

Contents

1	Device block diagram	2
2	Pin description	3
2.1	Pinout	3
2.2	Pin list	4
3	Electrical specifications	5
3.1	Absolute maximum ratings	5
3.2	Thermal data	5
3.3	Recommended operating conditions	5
3.4	Electrical specifications	5
4	Characterization curves	7
4.1	Test circuit	7
4.2	Characterization curves	8
4.2.1	For $R_L = 6 \Omega$	9
4.2.2	For $R_L = 8 \Omega$	10
5	Application information	11
5.1	Application circuit	11
5.2	Mode selection	11
5.3	Gain setting	12
5.4	Input resistance and capacitance	12
5.5	Internal and external clocks	13
5.5.1	Master mode (internal clock)	13
5.5.2	Slave mode (external clock)	13
5.6	Output low-pass filter	14
5.7	Protection functions	15
5.8	Diagnostic output	15
6	Package information	16
6.1	PowerSSO-36 EPU package information	16
	Revision history	18

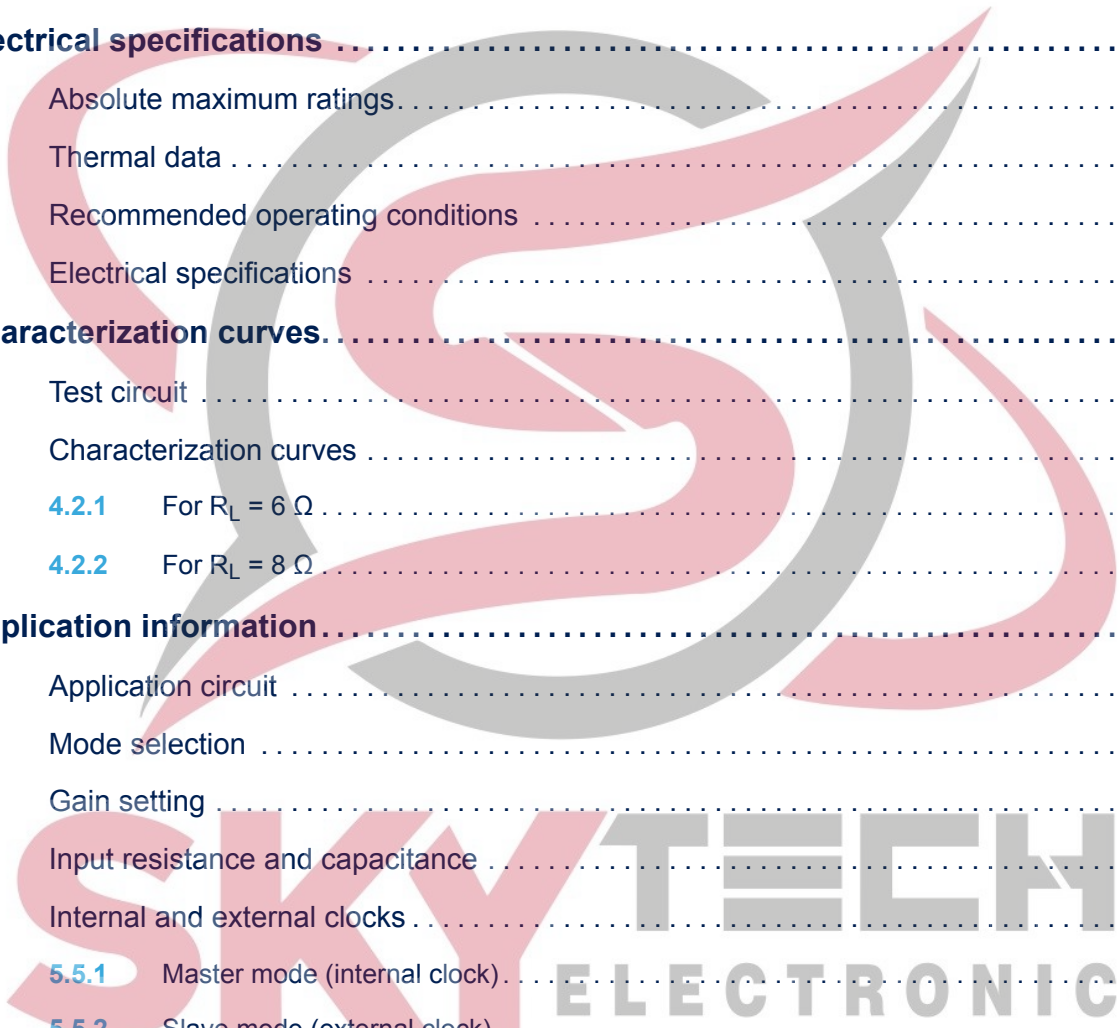

List of tables

Table 1.	Pin description list	4
Table 2.	Absolute maximum ratings	5
Table 3.	Thermal data	5
Table 4.	Recommended operating conditions	5
Table 5.	Electrical specifications	5
Table 6.	Mode settings	11
Table 7.	Gain settings	12
Table 8.	How to set up SYNCLK	13
Table 9.	PowerSSO-36 EPU package mechanical data	17
Table 10.	Document revision history	18



List of figures

Figure 1.	Internal block diagram (showing one channel only)	2
Figure 2.	Pin connections (top view, PCB view)	3
Figure 3.	Test circuit for characterizations	7
Figure 4.	Test board	8
Figure 5.	Output power (THD = 10%) vs. supply voltage	9
Figure 6.	THD vs. output power	9
Figure 7.	THD vs. frequency (1 W)	9
Figure 8.	THD vs. frequency (100 mW)	9
Figure 9.	Frequency response	9
Figure 10.	FFT performance (0 dBFS)	9
Figure 11.	FFT performance (-60 dBFS)	9
Figure 12.	Output power (THD = 10%) vs. supply voltage	10
Figure 13.	THD vs. output power	10
Figure 14.	THD vs. frequency (1 W)	10
Figure 15.	THD vs. frequency (100 mW)	10
Figure 16.	Frequency response	10
Figure 17.	FFT performance (0 dB)	10
Figure 18.	FFT performance (-60 dB)	10
Figure 19.	Application circuit for 6 Ω or 8 Ω speakers	11
Figure 20.	Standby and mute circuits	12
Figure 21.	Turn on/off sequence for minimizing speaker "pop"	12
Figure 22.	Input circuit and frequency response	13
Figure 23.	Master and slave connection	14
Figure 24.	Typical LC filter for an 8 Ω speaker	14
Figure 25.	Typical LC filter for a 6 Ω speaker	14
Figure 26.	Behavior of pin DIAG for various protection conditions	15
Figure 27.	PowerSSO-36 EPU package outline	16

SKYTECH
ELECTRONIC

IMPORTANT NOTICE – PLEASE READ CAREFULLY

STMicroelectronics NV and its subsidiaries (“ST”) reserve the right to make changes, corrections, enhancements, modifications, and improvements to ST products and/or to this document at any time without notice. Purchasers should obtain the latest relevant information on ST products before placing orders. ST products are sold pursuant to ST’s terms and conditions of sale in place at the time of order acknowledgement.

Purchasers are solely responsible for the choice, selection, and use of ST products and ST assumes no liability for application assistance or the design of Purchasers’ products.

No license, express or implied, to any intellectual property right is granted by ST herein.

Resale of ST products with provisions different from the information set forth herein shall void any warranty granted by ST for such product.

ST and the ST logo are trademarks of ST. For additional information about ST trademarks, please refer to www.st.com/trademarks. All other product or service names are the property of their respective owners.

Information in this document supersedes and replaces information previously supplied in any prior versions of this document.

© 2020 STMicroelectronics – All rights reserved



SKYTECH
ELECTRONIC